

Boormal *Schaal 1:1*
Drill pattern *Scale 1:1*
Bohrschablone *Maßstab 1:1*
Gabarit *Echelle 1:1*
Plantilla de perforación *Escala 1:1*
Dima di foratura *Scala 1:1*

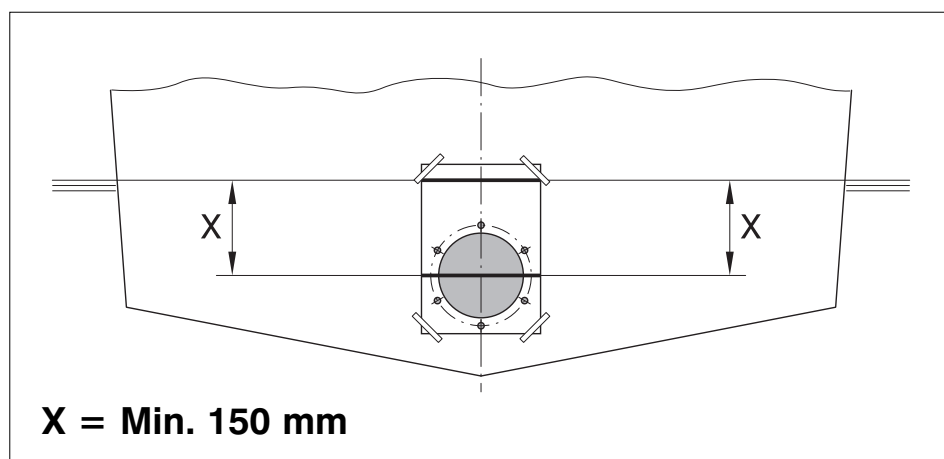

WATERLIJN
 WATERLINE
 WASSERLINIE

LIGNE DE FLOTTAISON
 LÍNEA DE FLOTACIÓN
 LINEA DI GALLEGGIAMENTO

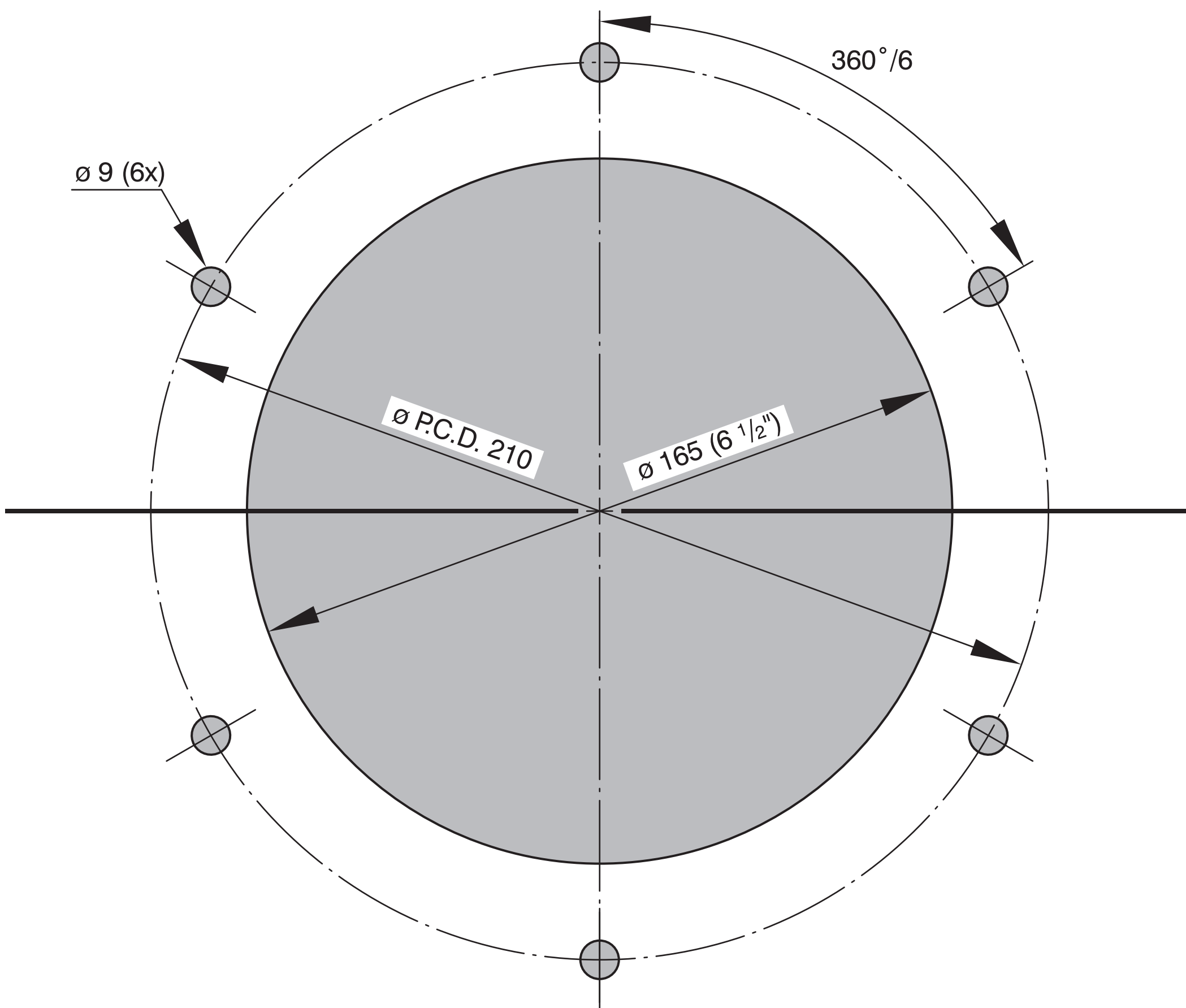

Hoofdafmetingen

Dimensions principales



Principal dimensions

Dimensiones principales

Hauptabmessungen

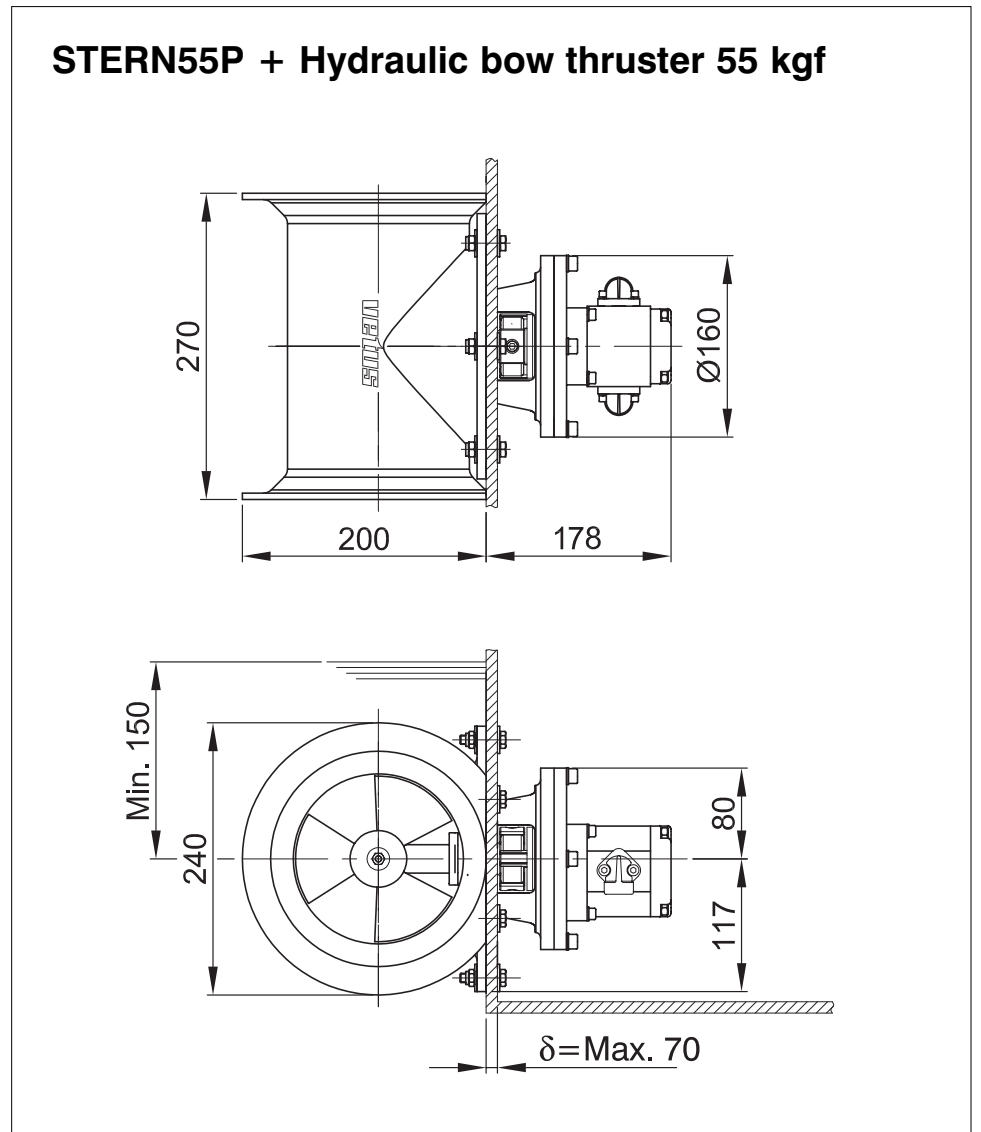
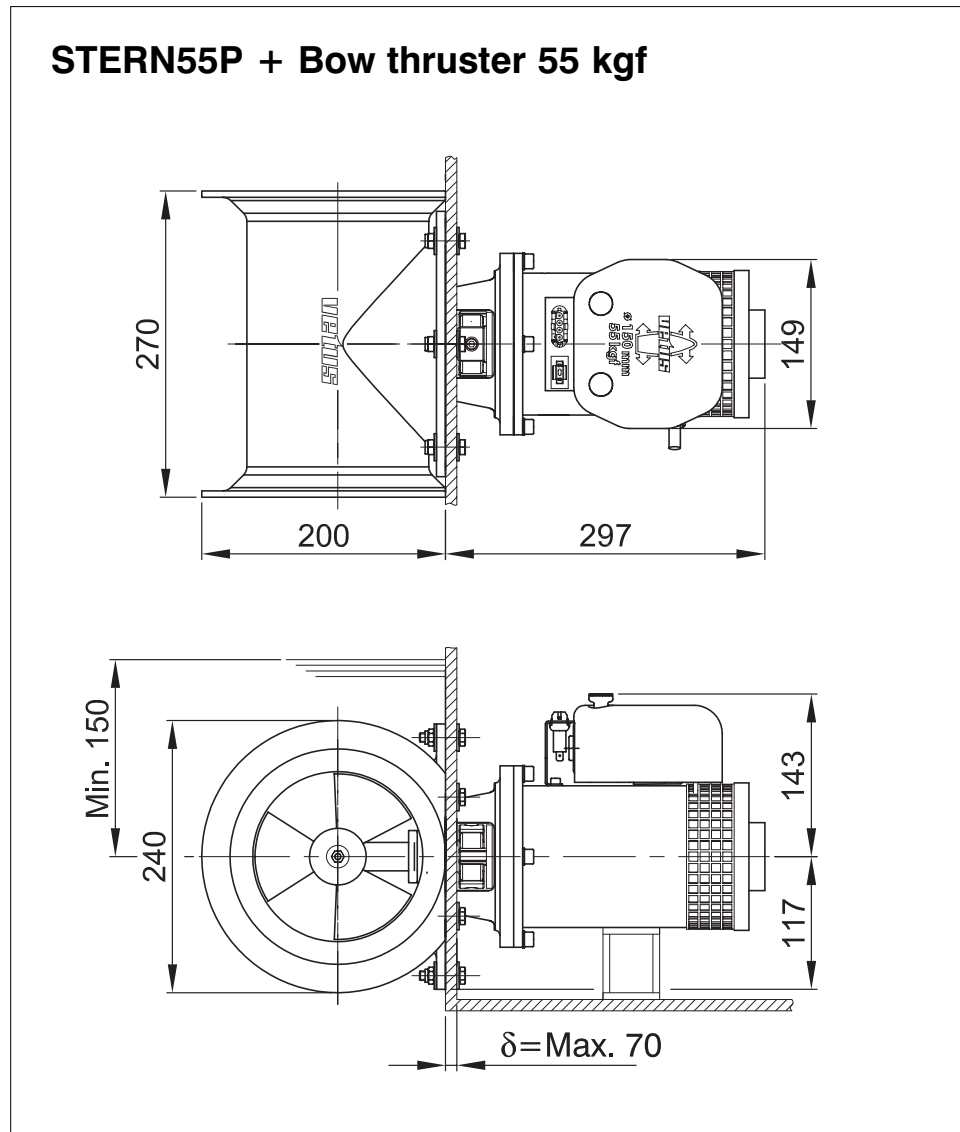
Dimensioni principali

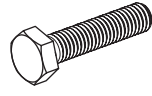

Bevestigingsbenodigheden Befestigungsmaterial Material de fijación		Fixing needs Matériel de fixation Dispositivi di fissaggio	
Zeskantbout Hexagon head bolt Sechskantschrauben Vis à tête hexagonale Tornillos de cabeza hexagonal Bullone a testa esagonale	Zelfborgende zeskantmoer Self locking hexagon nut Sechskant-Sicherungsmuttern Écrous auto-freines hexagonaux Tuercas hexagonales de seguridad Dado esagonale autobloccante	Vlakke sluitring Plain washer Flache Scheibe Rondelles plates Arandelas planas Rondelle	
6 x  M8 (5/16")	6 x  M8 (5/16")	12 x  ø 8 x ø 24	
• RVS A4 • Acier inoxydable A4	• Stainless Steel A4 • Acero inoxidable A4	• Edelstahl A4 • Acciaio inossidabile A4	

Deze bevestigingsbenodigheden worden niet meegeleverd, maar dienen apart te worden aangeschaft.
These fixing needs are not supplied, but must be ordered separately.
Diese Befestigungsmaterialien werden nicht mitgeliefert, sondern müssen extra gekauft werden.
Ce matériel de fixation n'est pas fourni et doit donc être acheté séparément.
Este material de fijación no está incluido por lo que debe adquirirse por separado.
Questi dispositivi di fissaggio non sono in dotazione e devono essere acquistati separatamente.

Wanddikte δ Hull thickness δ Stärke der Schiffshaut δ Épaisseur du bordé δ Espesor de la borda δ Spessore della paratia δ	δ < 15	7 < δ < 25	17 < δ < 35
	L=40	L=50	L=60