

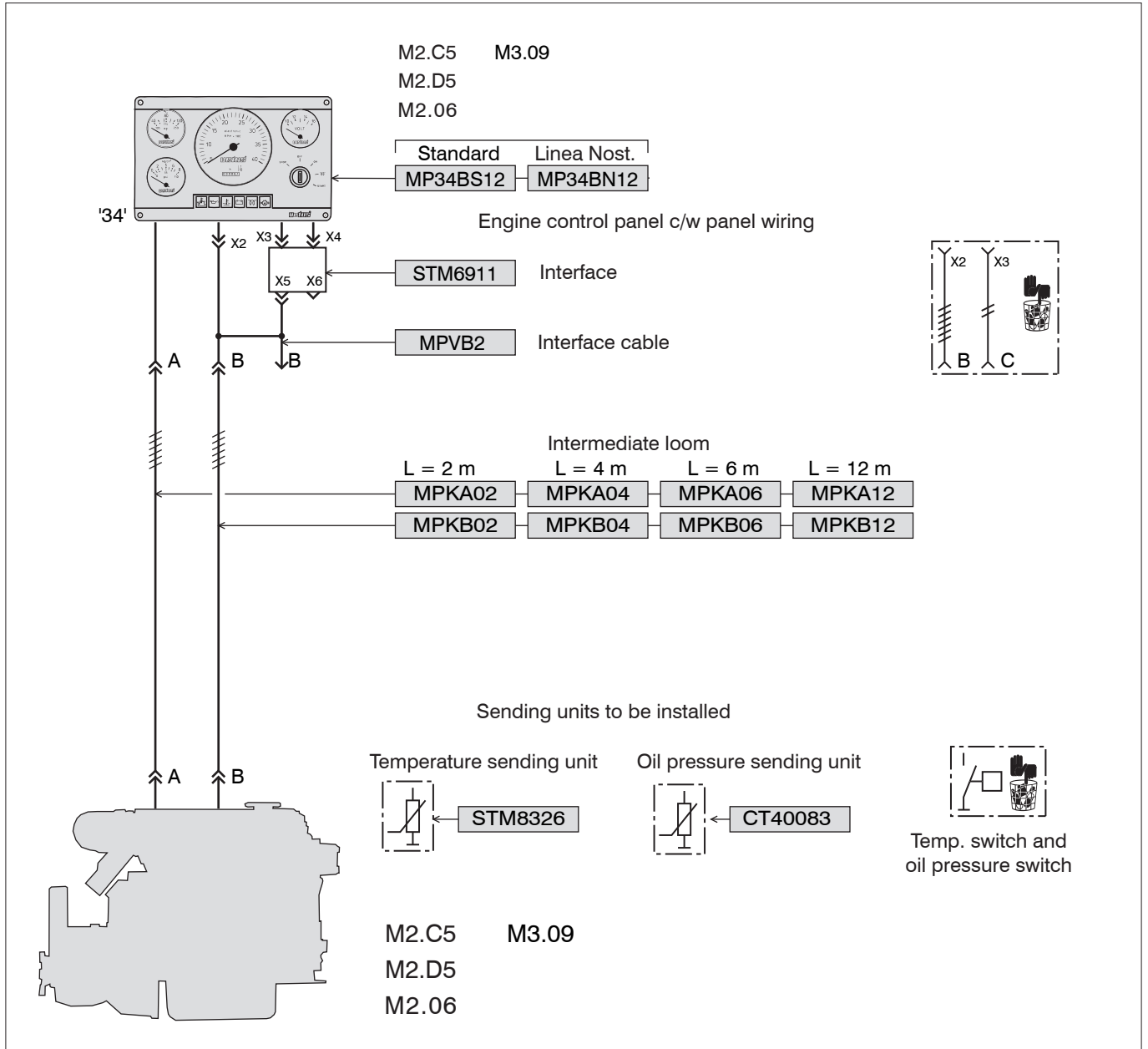

MP34 ⇔

M2.C5
M2.D5
M2.06
M3.09

Installation
instructions



When using a panel model '34' both warning lights and meters, for coolant temperature and oil pressure have to be operated.

Installation of both switches for warning lights and sending units for meters into the engine block is not possible. Therefore some minor modifications have to be carried out:

- At the panel the factory installed connection cables (X2->B and X3->C) have to be replaced by an interface [STM 6911] and an interface cable [MPVB2].
- At the engine the factory installed switches have to be replaced by sending units, adaptors and washers are required.

Installation of interface and interface cable on '34' model panel

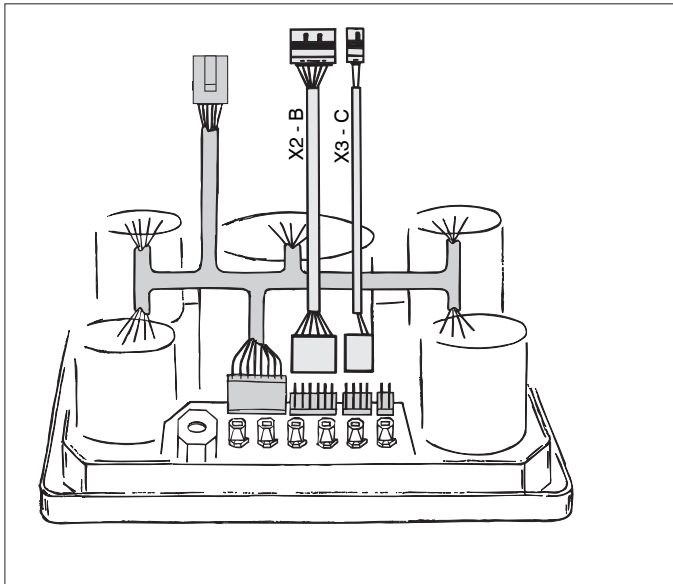

On panel, remove connection cables, X2 ↔ B and X3 ↔ C, from warning light printed circuit board (pcb).

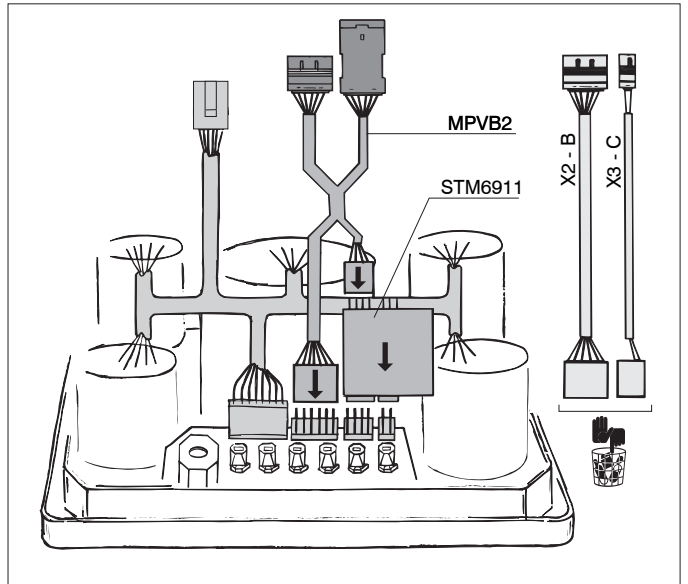

Install interface pcb [STM6911] onto warning light pcb. Connect Interface cable [MPVB2] to warning light pcb and to interface pcb.

Replacing switches for sending units

- On engine, loosen wire nr. B5 (blue) from the thermo switch.
Replace factory installed thermo switch by: Temperature sending unit, adaptor and copper washers. Reconnect wire B5 to temperature sensor.
- Loosen wire nr. B2 (brown) from the oil pressure switch.
Replace factory installed oil pressure switch by: Oil pressure sending unit and adaptor. Reconnect wire B2 to oil pressure sensor.

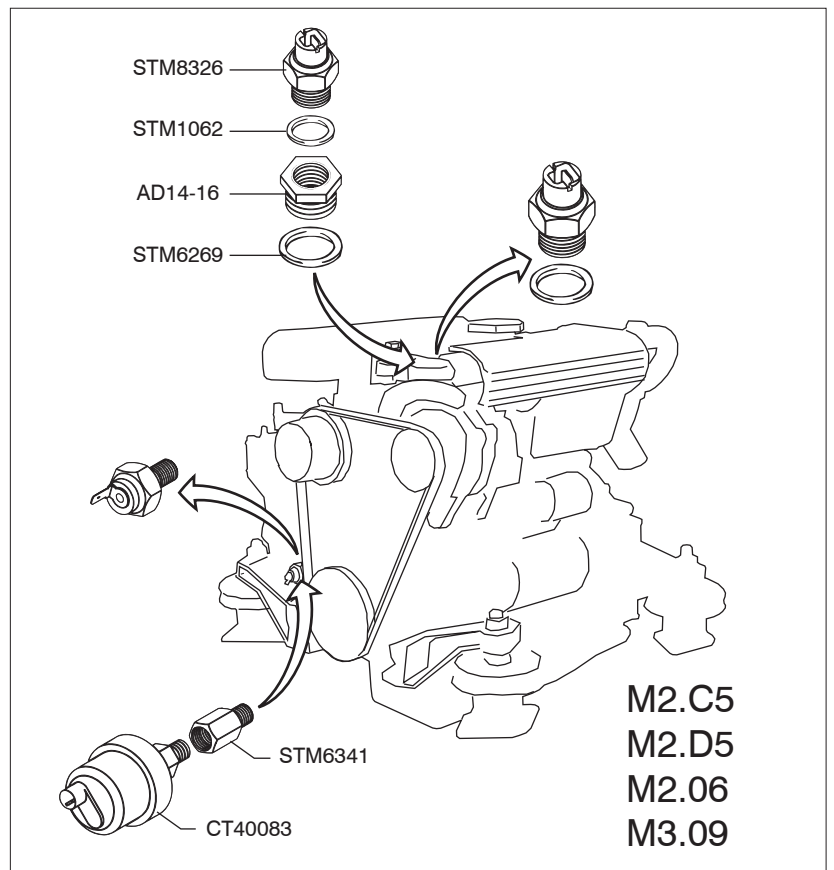

Vetus n.v.

FOKKERSTRAAT 571 - 3125 BD SCHIEDAM - HOLLAND - TEL.: +31 10 4377700
 TELEFAX: +31 10 4372673 - 4621286 - E-MAIL: sales@vetus.nl - INTERNET: http://www.vetus.com